

CAD FILE:

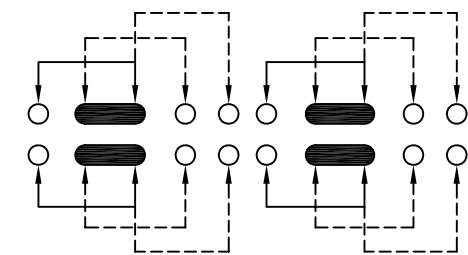

SCHEMATIC (SHORTING)

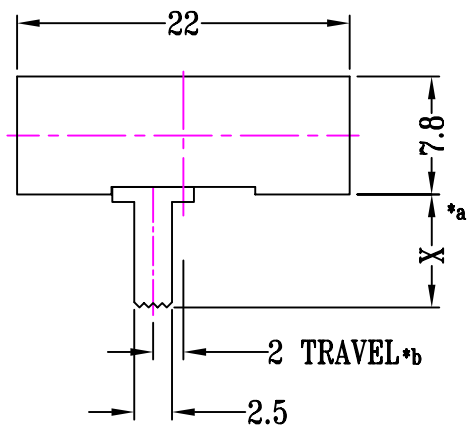
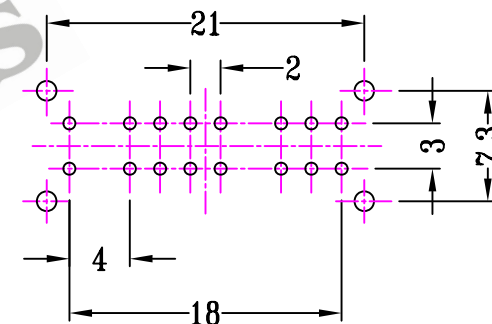
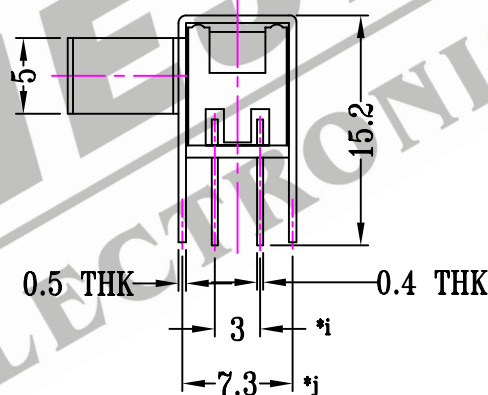
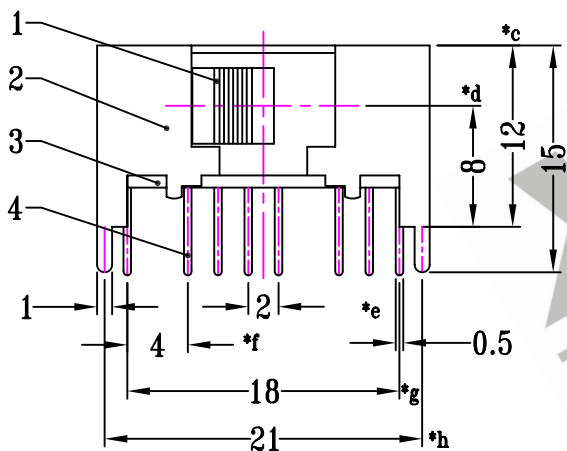

P.C.B LAYOUT

注：“*”表示关键尺寸（10个）

NO.	PARTS	MATERIALS	Q'TY	FINISH	TOLERANCE UNLESS SPECIFIED	SHENZHEN XIEJIA ELECTRONICS CO.,LTD.				
8						TITLE : HORIZONTAL SLIDE SWITCH MODEL: SK-43D14				
7	STEEL BALL	STEEL	1	NATURAL	WITHIN: 1.5±0.1mm OVER: 1.5±0.2mm					ISSUE
6	SPRING	STEEL WIRE	1	TEMPER		UNIT : mm	DRWG NO.: SF-DR-SK43D14-00			
5	CONTACT CLIP	PBS STRIP	4	Ag PLATED		SCALE: 2:1	DWN.	ZHOUYU	2005-4-5	
4	TERMINAL	BRASS STRIP	16	Ag PLATED OVER Ni PLATED		CHK'D	FANGYING	2005-4-5		
3	BASE	PHENOLIC RESIN	1	NATURAL		APPD.	KANGXINAN	2005-4-5		
2	FRAME	STEEL STRIP	1	Ni PLATED		ALL MATERIALS MUST BE COMPLIANT TO ROHS				
1	KNOB	POM	1	BLACK						